

SCALE 3 : 1

# INFORMATION IN THIS DRAWING PROVIDED FOR REFERENCE ONLY

REVISIONS				
ZONE	REV.	DESCRIPTION	DATE	APPROVED

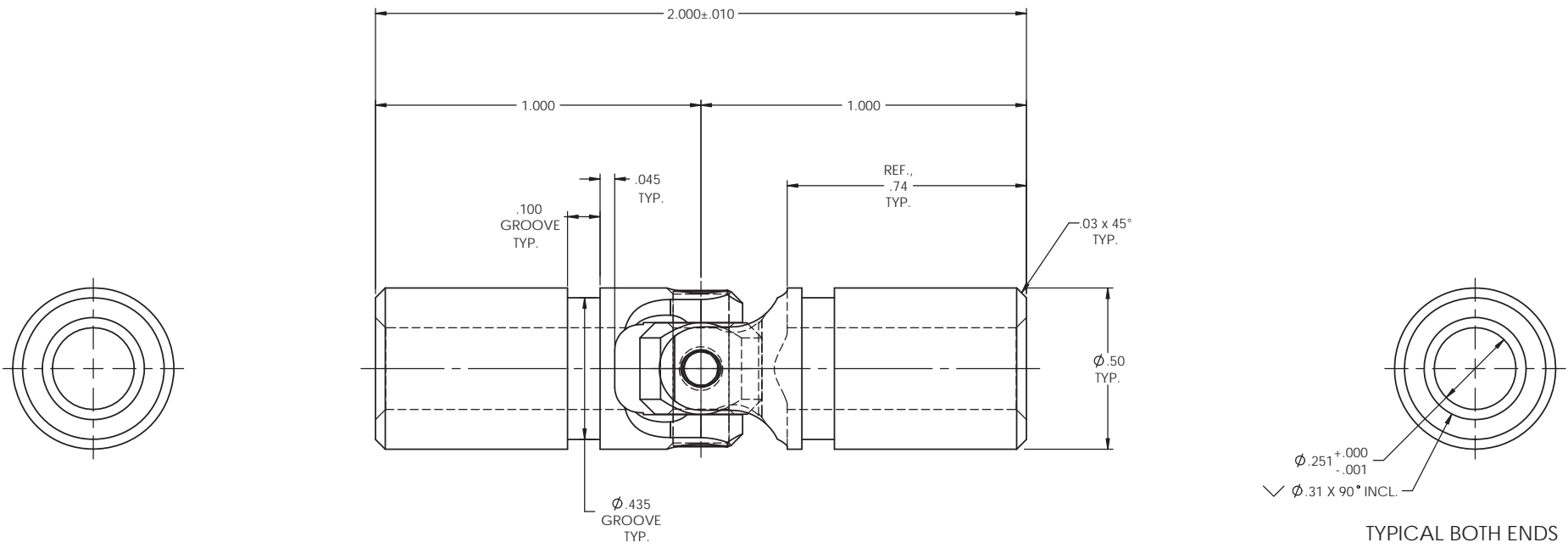

TYPICAL BOTH ENDS

NOTE(s), UNLESS OTHERWISE SPECIFIED.

- (1) UNIVERSAL JOINT IS MARKED w/ "BELDEN" LOGO, PART NUMBER / DRAWING NUMBER, REVISION LEVEL (IF ANY), DATE OF MANUFACTURE (MO/YR), AND BELDEN JOB NUMBER.
- (2) UNIVERSAL JOINT IS LUBRICATED w/ LUBRIPLATE 1200-2, NLGI GRADE 2, AW/EP, LITHIUM GREASE OR EQUIVALENT.
- (3) UNIVERSAL JOINT IS CAPABLE OF OPERATING AT ANY ANGLE UP TO AND INCLUDING 45°.
- (4) UNIVERSAL JOINT HAS STANDARD GROOVES TO ACCEPT INSTALLATION OF PROTECTIVE COVER (BOOT). BOOT AVAILABLE SEPARATELY. REFER TO BELDEN CATALOG, WEBSITE, OR CONTACT BELDEN SALES.
- (5) REFER TO BELDEN CATALOG, WEBSITE, OR CONTACT BELDEN SALES FOR TORQUE CAPACITY.
- (6) THIS DRAWING REPRESENTS A STANDARD BELDEN ITEM. CUSTOM UNIVERSAL JOINTS ARE AVAILABLE UPON REQUEST. PLEASE CONTACT BELDEN SALES.

**BELDEN PART NUMBER: UJ-HD500x250**

DO NOT SCALE DRAWING

UNLESS OTHERWISE SPECIFIED CHAMFER ALL HOLES BREAK ALL SHARP CORNERS DE-BURR ALL FEATURES TURNED SURFACES: $\checkmark_{6/3}$ MILLED SURFACES: $\checkmark_{125}$ PROPRIETARY AND CONFIDENTIAL THE INFORMATION CONTAINED IN THIS DRAWING IS THE SOLE PROPERTY OF BELDEN INCORPORATED. ANY REPRODUCTION IN PART OR AS A WHOLE WITHOUT THE WRITTEN PERMISSION OF BELDEN INCORPORATED IS PROHIBITED.	STANDARD TOLERANCES, UNLESS OTHERWISE SPECIFIED DIMENSIONS ARE IN INCHES [mm]	MATERIAL: ALLOY STEEL HEAT TREAT: SEE DETAIL DRAWINGS FINISH: NONE	NAME: JP DATE: 23MAR12 CHECKED: RNK 09APR12 ENG APPR: RNK 09APR12 MFG APPR: D/A: COMMENTS:	Belden Incorporated <a href="http://www.beldenuniversal.com">www.beldenuniversal.com</a> TITLE: ASSEMBLY, UNIVERSAL JOINT SIZE: C DWG. NO.: UJ-HD500x250 SCALE: 4:1   WT (Lbs): 0.073   SHEET 1 OF 2	
	ANGULAR MACHINED: $\pm 1.0^\circ$ FRACTIONAL: $\pm 0.15$ TWO PLACE DECIMAL: $\pm 0.10$ THREE PLACE DECIMAL: $\pm 0.05$ FOUR PLACE DECIMAL: $\pm 0.005$ CONCENTRICITY: $0.0025$ T.I.R.	ALL HOLES TO BE LOCATED ON CENTERLINE (C) WITHIN .005" T.I.R. INTERPRET GEOMETRIC TOLERANCES I.A.W. ANSI Y14.5M-1992	HEAT TREAT: SEE DETAIL DRAWINGS	DRAWN: JP DATE: 23MAR12	REV:
	UNLESS OTHERWISE SPECIFIED CHAMFER ALL HOLES BREAK ALL SHARP CORNERS DE-BURR ALL FEATURES TURNED SURFACES: $\checkmark_{6/3}$ MILLED SURFACES: $\checkmark_{125}$ PROPRIETARY AND CONFIDENTIAL THE INFORMATION CONTAINED IN THIS DRAWING IS THE SOLE PROPERTY OF BELDEN INCORPORATED. ANY REPRODUCTION IN PART OR AS A WHOLE WITHOUT THE WRITTEN PERMISSION OF BELDEN INCORPORATED IS PROHIBITED.	STANDARD TOLERANCES, UNLESS OTHERWISE SPECIFIED DIMENSIONS ARE IN INCHES [mm]	MATERIAL: ALLOY STEEL HEAT TREAT: SEE DETAIL DRAWINGS FINISH: NONE	NAME: JP DATE: 23MAR12 CHECKED: RNK 09APR12 ENG APPR: RNK 09APR12 MFG APPR: D/A: COMMENTS:	Belden Incorporated <a href="http://www.beldenuniversal.com">www.beldenuniversal.com</a> TITLE: ASSEMBLY, UNIVERSAL JOINT SIZE: C DWG. NO.: UJ-HD500x250 SCALE: 4:1   WT (Lbs): 0.073   SHEET 1 OF 2
	ANGULAR MACHINED: $\pm 1.0^\circ$ FRACTIONAL: $\pm 0.15$ TWO PLACE DECIMAL: $\pm 0.10$ THREE PLACE DECIMAL: $\pm 0.05$ FOUR PLACE DECIMAL: $\pm 0.005$ CONCENTRICITY: $0.0025$ T.I.R.	ALL HOLES TO BE LOCATED ON CENTERLINE (C) WITHIN .005" T.I.R. INTERPRET GEOMETRIC TOLERANCES I.A.W. ANSI Y14.5M-1992	HEAT TREAT: SEE DETAIL DRAWINGS	DRAWN: JP DATE: 23MAR12	REV: